

ORGANISATION AND USE OF NON-PRINT MATERIALS IN LIBRARIES: A STUDY OF SELECTED UNIVERSITY LIBRARIES OF ANDHRA PRADESH

Dr.B.Vijaya Kumar

Librarian, Sri Venkateswara Institute of Medical Sciences University, Tripathi

Prof. K. Padmini

Professor, Department of Library and Information Science,
Sri Venkateswara University, Tripathi.

The main purpose of the academic library is to provide collections and services in support of higher education. The functions of universities are conservation of knowledge and ideas, teaching, publication, research, extension service and interpretation and thus, university libraries are very essential to achieve the objectives of university education.

The impact of information science during the last decades directly causes the spread of non-print and fugitive materials and as a result, libraries world over have acquired large collections of such materials. There are several reasons for procuring non-print materials in university libraries. Such materials are acquired to support teaching and research and to supplement traditional printed “learning resources.” These materials are connected to curriculum. Infact, these materials carry the nascent information of very recent origin which are the products of cross disciplinary research in different fields. This literature needs to be collected, organized and disseminated in right time. The information loses its dynamism if it is not communicated immediately. Time factor plays a vital role in the communication and information contained in non-print material formats. The importance of studying these media in their own right assumes a great significance as they become ever more essential to the infrastructure of the society. Hence the present study is the need of the hour.¹

DEFINITION OF NON-PRINT MATERIALS:

In 1976 British Standards Institution identified general terms included
Non-book materials and its synonyms, Audio-Visual materials and meta book;
Non-book media and its synonym non-print media;
Multimedia and its synonym non-print materials².

Audio-visual as examined by William peters is “an umbrella term covering practically all non-print materials which find their way into a library. Such non-print materials form, special collections in a library³.

In this present study an attempt is made to study the organization and use of non-print materials in university libraries of Andhra pradesh⁴.

Figure 1

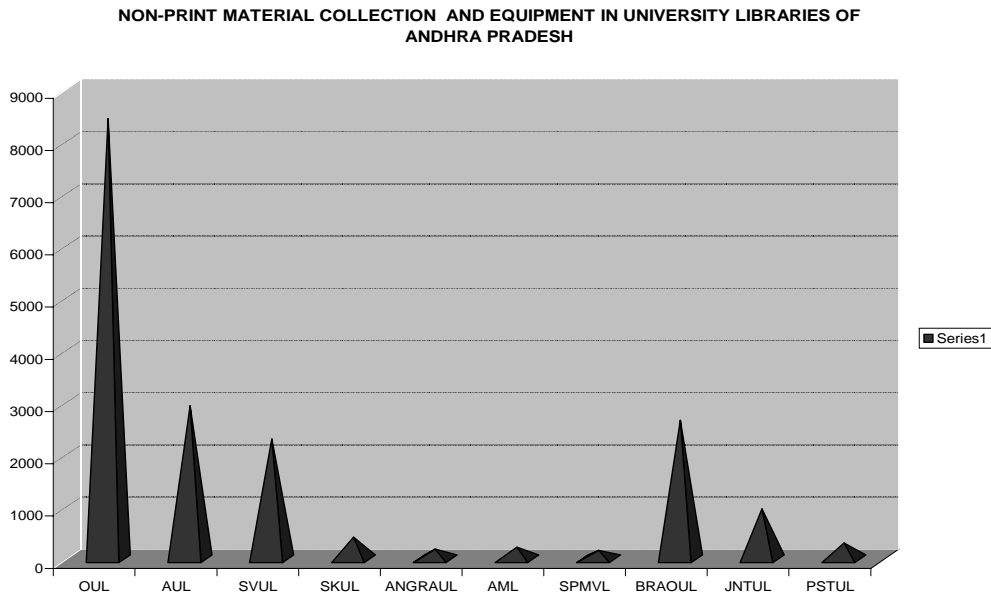

- OUL : Osmania University Library, Hyderabad
AUL : Andhra University Library, Visakhapatnam
SVUL : Sri Venkateswara University Library, Tirupati
SKUL : Sri Krishnadevaraya University Library, Anantapur
ANGRAUL : Acharya Nagarjuna Agriculture University Library, Hyderabad
AML : Ambedkar Memorial Library, Guntur
SPMVL : Sri Padmavathi Mahila Viswavidyalayam Library, Tirupati
BRAOUL : B.R.Ambedkar Open University Library, Hyderabad
JNTUL : Jawaharlal Nehru Technological University Library, Hyderabad
PSTUL : Pottisreeramulu Telugu University, Hyderabad.

The above graph shows the Non-print material and equipment in different university libraries of Andhra Pradesh.

SIGNIFICANCE

Non-print media have come to dominate administration, storage and communication in business and commerce and play a large part in sales and marketing. Over the next few years they will provide the major mechanism for recording events and archiving the activities of society. The importance of studying these media in their own right assumes a greater significance as they become ever more essential to the infrastructure of the society.

Keeping in view the above, the present topic has been chosen with an aim to study the role of non-print materials in academic libraries especially in university libraries. As many studies have been conducted relating to print media, the researcher felt that this is the right time to examine the importance of non-print materials in university libraries as the society is passing through a transitional stage from traditional information environment to electronic environment.

OBJECTIVES

- To study the acquisition, processing and maintenance of non-print materials in university libraries of Andhra Pradesh.
- To study the availability of non-print materials and equipment in university libraries.
- To find out the hindrances for better utilization of non-print materials in university libraries.
- To examine the views of the university librarians on the level of satisfaction relating to collection and utilization of non-print materials.

METHODOLOGY

There are 12 state university libraries in Andhra Pradesh. Among them 10 state university libraries are selected for the present study. The aim of the present work is to highlight the organization and use of non-print materials in university libraries. Questionnaire and interview methods are followed to collect data.

SCOPE AND LIMITATIONS

The scope of the present work extends to study the various types of non-print materials available in the state university libraries, how they are being acquired, organized and how best these materials are being utilized by users in the university libraries. Due to constraints of time and money involved the present study is restricted to 10 state university libraries of Andhra Pradesh.

ANALYSIS OF DATA

One state university library i.e Dr.B.R. Ambedkar Open University Library, Hyderabad mentioned that budget allotted for non-print materials is sufficient. Acharya N.G.Ranaga Agricultural University mentioned that budget allotted for non-print materials is not sufficient. Most of the university libraries mentioned that a separate budget for non- print materials is required.

A question is asked to know whether any selection committee for non-print materials in university libraries is existing. All the librarians replied that there is no selection committee for non-print materials.

Majority of the university libraries are selecting non-print materials through librarian on recommendations of subject specialists, followed by departmental library committee and library advisory committee.

Most of the university libraries are procuring non-print materials through distributors/agents Majority of the university libraries are not maintaining separate accession register for non-print materials. They are following specific methods like making note in the remarks column of accession register, specifying the type of material in brackets, noting down the kind of material

in the accession register, Kardex mentioning the kind of material against title, prefixing the serial number with initials of type of material.

Less number of university libraries are getting reading materials like encyclopedias and journals in CD-ROM formats.

Five state university libraries are classifying and cataloguing non-print materials. Those who are doing classification and cataloguing are following Dewey decimal classification and Anglo-American Cataloguing Rules-II respectively. The forms of catalogue are card form(2) Computerised form(2) book form(1). One state university library i.e Dr.B.R. Ambedkar Open University library is following keyword indexing technique for information retrieval in addition to classification and cataloguing.

Most of the university libraries are following closed access system for non-print materials. Jawaharlal Nehru Technological university and Potti Sreeramulu Telugu university are following open access system where as S.V.University Library is following open and closed access for non-print materials.

Most of the university libraries have no separate section for non print materials. Those libraries which are not having separate section, the responsibility of non-print materials are kept under the control of reference section.

Four state university libraries i.e. Osmania University library, Acharya N.G. Ranga Agricultural University library, Dr.B.R.Ambedkar Open University library and Jawaharlal Nehru technological university library are lending non-print materials to their users, i.e faculty and research scholars.

Two state university libraries i.e Osmania University library and Dr. B.R. Ambedkar Open university library are lending films, videocassettes to study centres through inter library loan.

Less number of university libraries have separate reading rooms for non-print materials. Those libraries which are having separate room are not satisfied with facilities like acoustical treatment, and humidity control and cooling system.

Most of the university libraries are not participating in cooperative activities mentioned reasons like lack of sufficient non-print materials and not necessary. Most of the university libraries are providing orientation for proper handling of non-print materials through different methods like lecture, library tour, library guides etc. Majority of the university libraries are publicizing non-print materials through various methods like displaying periodic list of new arrivals, circulating catalogue of the collection and list of arrivals, displaying latest arrivals separately. Most of the university libraries mentioned that absence of sufficient equipment and materials, lack of awareness about non-print materials are the hindrances for better utilization of non-print materials.

Figure 2

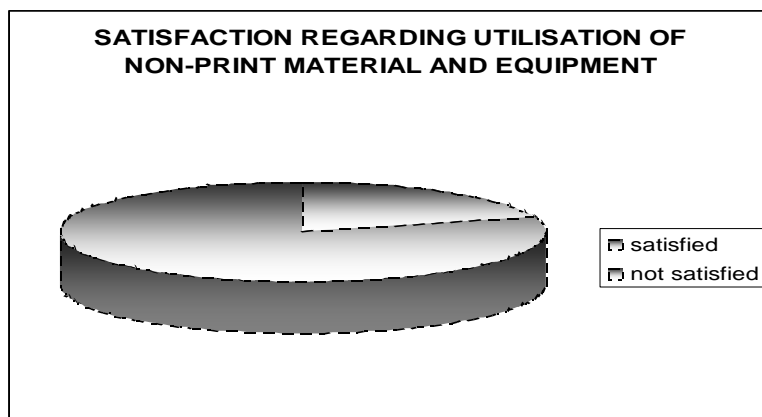

It is clear from the above table 1.3 that 2 state universities (20%) felt that the existing non-print material collection and equipment is sufficient and 8 state universities (80%) expressed their dissatisfaction with regard to collection of non-print material and equipment. The reasons for insufficiency of non-print materials in the libraries are lack of sufficient special grants, proper environment, lack of trained persons and lack of awareness among users.

Most of the university libraries are not verifying the non-print material stock. The various reasons expressed by the libraries are less use of non-print materials, lack of time and lack of man power.

Most of the university libraries are having internet facility. the internet access is allowed to users only in three state university libraries. The reason for less utilization is that it is not open to users in some university libraries.

Most of the university libraries mentioned that assessment of user needs is necessary. They are following different methods like survey, questionnaire and observation methods respectively to assess the needs of users.

RECOMMENDATIONS:

The following measures are suggested for better organization and utilization of non-print materials in university libraries.

- Separate allocation of funds exclusively to acquire and maintain non-print materials must be provided to university libraries.
- A selection committee for selection of non-print materials in university libraries must be appointed consisting of chief librarian, representatives from Arts and Sciences faculties, research scholars and students and library staff.
- Proper care and interest must be taken by the university library authorities to build up the
- Non-print material collection to meet the changing information requirement of their users to satisfy their demands relating to teaching and research.

- A full time, qualified and skilled person must be appointed for the care, maintenance and to provide assistance with regard to non-print materials. This will enable better utilization of non-print materials.
- Though many of the university libraries are publicizing their non-print materials, they are not reaching their target group properly. Hence better methods, like sending the existing non-print materials and also latest additional lists to the concerned departments can be followed.
- One time grant may be provided by UGC for the establishment of independent sections for non-print material in university libraries and recurring financial assistance may be provided for maintenance of the same. The efforts of UGC, which established INFLIBNET, in this regard are to be appreciated.
- Periodic training courses, on the campus and off the campus, for the library professionals/personnel in knowing the existing non-print material and in handling them, are to be organized by individual libraries and associations. These efforts will enrich the ability of information, providing skills of the library professionals/personnel.
- Orientation is necessary for the optimum use of non-print materials, short term orientation programmes can be organized by the libraries to create awareness among the users, about the available non-print materials and minimum techniques to use those materials.
- The educators have also their role to play for the better utilization of non-print materials by adopting library oriented teaching methods and using non-print materials in their teaching.
- The provision and use of non-print materials can be expected to increase steadily in university libraries.

In addition, the trend towards more compact formats is likely to continue and libraries will need to reasons positively to new technological developments in order to maintain the progress achieved during the past few years.

REFERENCES

1. Rout (RK) and Choudhary (BK). A Practical manual AACR-2 1998 revision: A text book of advanced cataloguing practice recommended for M.L.I.Sc 1997. Reliance Publishing house, Delhi. P.4-5.
2. Fothergill (Richard) Butchart (Ian). Non-Book materials in libraries: A practical guide.1990.clive bingley, London, P.3
3. William (Peters). Audio-Visual materials in the public library. LIBRARY TRENDS, 16: 1996: 241.
4. Association of common wealth universities. Common wealth universities year book 2000: A directory to the universities of common wealth and handbook of their associations. Vol. I. 75th edition; 2000, Association of common wealth universities, London. P.596-598.

---@ @ @---