

## MICROCONTROLLER BASED TOUCH SCREEN IN LIBRARY CATALOGUE SYSTEM

**V. Spandana**

M. Tech

Jawaharlal Nehru Technological University

Hyderabad

e-mail: [spandana.velamarthi@gmail.com](mailto:spandana.velamarthi@gmail.com)

### ABSTRACT

*In this era of information technology, human tend to develop better and more convenient lifestyle. Nowadays, almost all the systems are equipped with the technology which eases the human work by making systems automatic. This touch screen based library catalogue system has advantageous and becomes an important application in library. The system consists of microcontroller which is interfaced with input and output modules. The enhancements provided by this technology give the ease of control to the users. The system uses a small keypad to get books issued by inserting the student identity code and book identity code on the keypad menu. This code comes along with the menu. The signal will automatically be displayed on the screen of the librarian and the book will be issued directly.*

### I. INTRODUCTION

In today's society, the way in which we physically interact with electronic devices is changing how we focus our technological research. This change has led to many great advances, including the development of touch screen technology. Through the use of touch screen technology, the operator is given an alternative method of how one can interact with a device. This technology operates in three distinct ways: resistive systems, capacitive systems, and infrared system. The Smart book issue system introduced current and fast way to issue books. This paper investigates, discuss, and compare these different technologies, focusing on the differences in application, aspects of sustainability, as well as the positive and negative qualities. The system consists of microcontroller which is interfaced with the input and output modules. The work mainly aimed at designing completely automated book catalogue system in library with the help of touch screen sensors and a graphical LCD to provide user friendly environment of the user to register the selected book effectively. Library management system is designed and developed for a receipt and issuance of books in the library along with student's detail. The books received in the library are entered in the books entry form and the new student is entered in the student entry form. When the student wants to get the desired book the same is issued on the availability basis to the student. The issuance and due date for the returning of the book is also entered in the book issue form under third menu book issue. The student has to pay the fine if any on the basis of book number of days delayed deposit of the book in the library.

**II. RELATED WORK:**

Numerous research works already exist in the literature that makes use of touch screen based library catalogue system important papers are reviewed below:

Design of wireless sensor network node on ZigBee for temperature monitoring”, advances in computing, control & telecommunication technologies, 2009[1]. In this paper a portable wireless data logging system for temperature monitoring in real time process dynamics. Process variables (like temperature, pressure, flow, level) vary with time in certain applications and these variations should be recorded so that a control action can take place at a defined set point. This paper proposes a 8-bit embedded platform for a temperature sensor node having a network interface using the 802.15.4 ZigBee protocol, that is a wireless technology developed as open global standard to address the low-cost, low-power wireless sensor networks. The wireless temperature sensor node senses and transmits the variations in the local temperature to the central computing unit placed within the range. The central base station receives the data and stores it in the file and plotting the variations simultaneously. Design of the restaurant self service ordering system based on ZigBee technology”, wireless communications networking and mobile computing, 2010[2]. Compare with the traditional food enterprise management mode, wireless self-service ordering management information system realizes the intellectualized and informationalized restaurant management. We design a self-service ordering node including its software and hardware. The touch screen displays the taste and prices of the food for customers to input their orders directly by touching. The system automatically completes data receiving, storage, display, and analysis. It's provided with many advantages as great flexibility, portability and etc, and has a widely spread of application prospects.

**III. PROBLEM DEFINITION**

Library book issue system is time taking and operator efficiency dependent in every institute. There is need of a design which is a completely automated. For the purpose of same a book catalogue system for library has to be designed with the help of touch screen sensor and a graphical LCD to control and provide a user-friendly environment of the user to register the selected book effectively through wireless.

Touch screens provide fast access to any and all types of digital media, with no text-bound interface getting in the way. Faster input can mean better service and using a properly designed touch interface can improve each other's efficiency, increase operator accuracy, reduce training time, Touch screens are practical in automation, which has become even simpler with touch screen technology. Owners familiar with the icon system appreciate touch screens that make automation systems user friendly [4]. In this system the library catalogue should be displayed automatically on the GLCD display and student can directly select the book with the help of touch screen.

**IV. METHODOLOGY**

This work mainly aims in designing completely automated books catalogue system in library with the help of touch screen sensor and a graphical LCD to control and provide a user-friendly environment of the user to register the selected book effectively. The library catalogue will be displayed automatically on the GLCD display and we can directly select the book with the help of touch screen.

The device consists of a microcontroller, which is interfaced with the input and output modules, the controller acts as an intermediate medium between both of them. So the controller can be termed as a control unit. The input module is nothing but a touch screen sensor, which takes the input from the user and provides the same to the microcontroller. The output module is the RF module. The controller also takes the responsibility to display the book catalogue information on the graphical LCD. At the receiving end the selected books will be displayed on GLCD.

The building blocks of the system are:

- Regulated power supply.
- Touch screen sensor with driver.
- Two microcontroller modules.
- RF transmitter.
- RF receiver.
- Reset.
- Crystal oscillator.
- LED Indicator.

**Hardware Used:**

- PIC 16F877A
- Resister
- Capacitor
- Diodes
- Crystal
- Buzzer
- RF module
- LCD
- Touchscreen

**Software Used:**

- PIC-C compiler for embedded C programming.
- PIC kit to programmer for dumping code into micro-controller.
- Proteus for hardware simulation.
- RF Technology.

**V. BLOCK DIAGRAM OF PROJECT**

The Block Diagram of the system consists of microcontroller which is interfaced with the input and output modules.

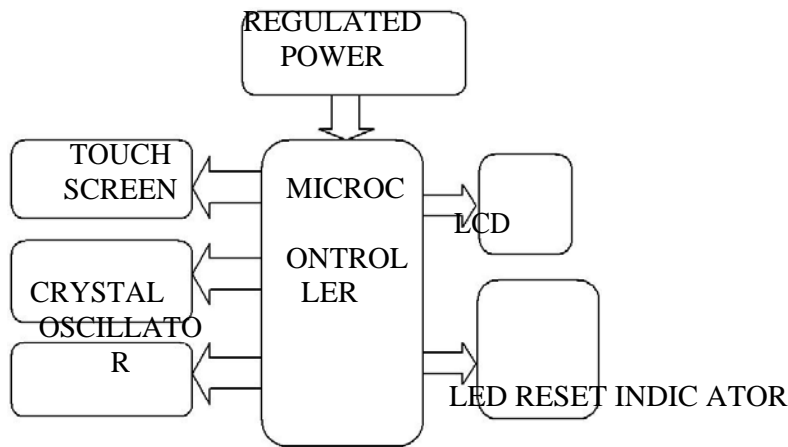
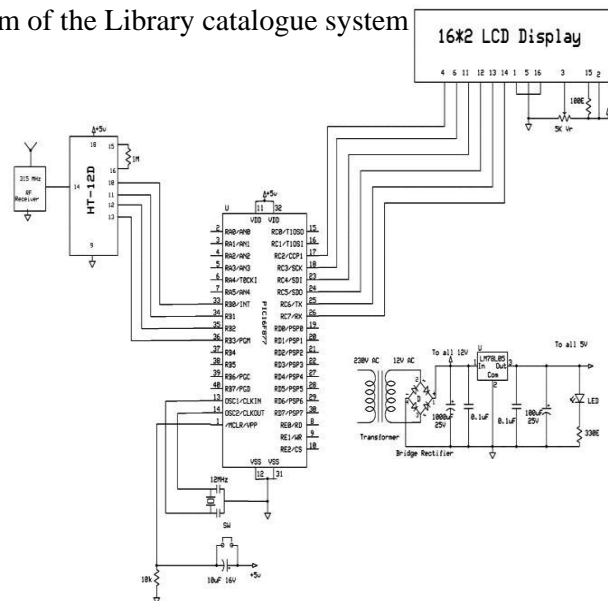

Fig1: Block Diagram of the Library catalogue system



The device consists of a microcontroller, which is interfaced with the input and output modules, the controller acts as an intermediate medium between both of them. So the controller can be termed as a control unit. The input module is nothing but a touch screen sensor, which takes the input from the user and provides the same to the micro-controller. The controller also takes the responsibility to display the book catalogue information on the graphical LCD. At the receiving end the selected books will be displayed on GLCD

**VII. RESULT**

Library management system is designed and developed for a receipt and issuance of books in the library along with student’s detail. The books received in the library are entered in the books entry form and the new student is entered in the student entry form. When the student wants to get the desired book the same is issued on the availability basis to the student. The issuance and due date for the returning of the book is also entered in the book issue form

under third menu book issue. The student has to pay the fine if any on the basis of book no. of days delayed deposit of the book in the library. This work can be used in library for the students. By using this work students can register the book immediately. The library catalog will be displayed automatically on the GLCD and book can directly be selected with the help of touch screen. The touch screen provides fast access to any and all types of digital media and hence minimize the rush in library.

### **VIII. CONCLUSION**

The work mainly aims in designing completely automated books catalog system in library. This work hence has ability to grow with number of applications and utility.

As library is regarded as the brain of any institute, many institutes understand the importance of library for the growth of institute and their esteem users (student). The implementation of touch screen library system gives the all detailed information about students, staff and books. It will track on the idea of how many books are available in library and book issued to the students. The project is customizable for any library requirement.

This work on "Library Management" deals with the transaction happenings in library in an organisation/institute. This work will be proved easier, as more of the tasks obtained are managed by a touch screen. The final report and other facilities and calculations are calculated and updated automatically. Therefore the main idea of this work is to create a manually operated system which is easily accessible by the student.

### **IX. FUTURE SCOPE**

Moving towards the future, consumers will continue to see the growth of the touch screen industry, due to extensive engineering advancements in user interfaces. The ability to physically touch a screen is easier than searching for a specific key in a sea of buttons. Society, for these reasons, has found touch screen to be the future of many devices.

#### **Restaurant**

With little bit modification this project can be the used in restaurant, for automatic menu display and ordering system

#### **Bank**

This work can be used in banks for the money transfer

### **REFERENCES**

1. Veerasingam, S.; Karodi, S.; Shukla, S.; Yeleti, M.C., "Design of Wireless Sensor Network Node on ZigBee for Temperature Monitoring," Advances in Computing, Control, & Telecommunication Technologies, 2009. ACT '09. International Conference on , vol., no., pp.20,23, 28-29 Dec. 2009
2. Sun Guiling; Qingqing Song, "Design of the Restaurant Self-Service Ordering System Based on ZigBee Technology," Wireless Communications Networking and Mobile Computing (WiCOM), 2010 6th International Conference on, vol., no., pp.1,4, 23-25 Sept. 2010.

3. Hashim, Nik Mohd Zarifie and Ali, Nur Alisa and Ja'afar, Abd Shukur and Mohamad, Najmiah Radiah and Salahuddin, Lizawati and Ishak, Noor Asryran (2013) Smart Ordering System via Bluetooth. *International Journal of Computer Trends and Technology (IJCTT)*, 4 pp. 2253-2256.
4. Hsu, Andrew. "Choosing a touch technology for handheld-system applications." *EDN*, January 8, 2009: 40-44.
5. "Company history from Elographics to EloTouchSystems, 1971 - present - EloTouchSystems - Tyco Electronics". <http://www.elotouch.com/AboutElo/History/default.asp>. Accessed 3 March 2010.
6. Jones, Willie D. "Touch Screens with Feeling" *IEEE Spectrum* May. 2009: 15. Accessed 3 March 2010.
7. S.H. Shete "GSM Enabled Embedded system for Energy Measurement And Billing" *International Journals of scientific & engineering Research*, Volume 4, Issue 1 January-2013 1 ISSN 2229 -5518
8. *International journal of computer trends and technology*-vol.11 number 5, may 2014.

---@@@---